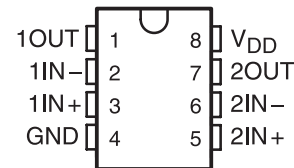
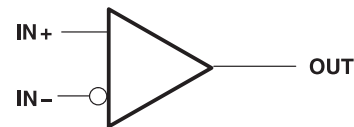

DUAL MICROPPOWER LinCMOS™ VOLTAGE COMPARATORS

Check for Samples: [TLC3702-Q1](#)

FEATURES

- Qualified for Automotive Applications
- ESD Protection Exceeds 2000 V Per MIL-STD-883, Method 3015; Exceeds 100 V Machine Model (C = 200 pF, R = 0); Exceeds 1500 V Charged Device Model (C = 200 pF, R = 0)
- Push-Pull CMOS Output Drives Capacitive Loads Without Pullup Resistor, $I_O = \pm 8$ mA
- Very Low Power . . . 100 μ W Typ at 5 V
- Fast Response Time . . . $t_{PLH} = 2.7$ μ s Typ With 5-mV Overdrive
- Single-Supply Operation . . . 3 V to 16 V
- On-Chip ESD Protection

**D OR PW PACKAGE
(TOP VIEW)**

SYMBOL (EACH COMPARATOR)

DESCRIPTION

The TLC3702 consists of two independent micropower voltage comparators designed to operate from a single supply and be compatible with modern HCMOS logic systems. They are functionally similar to the LM339 but use one-twentieth of the power for similar response times. The push-pull CMOS output stage drives capacitive loads directly without a power-consuming pullup resistor to achieve the stated response time. Eliminating the pullup resistor not only reduces power dissipation, but also saves board space and component cost. The output stage is also fully compatible with TTL requirements.

Texas Instruments LinCMOS™ process offers superior analog performance to standard CMOS processes. Along with the standard CMOS advantages of low power without sacrificing speed, high input impedance, and low bias currents, the LinCMOS™ process offers extremely stable input offset voltages with large differential input voltages. This characteristic makes it possible to build reliable CMOS comparators.

The TLC3702Q is characterized for operation over the full automotive temperature range of -40°C to 125°C .

ORDERING INFORMATION⁽¹⁾

| T_A | PACKAGE ⁽²⁾⁽²⁾ | | ORDERABLE PART NUMBER | TOP-SIDE MARKING |
|--|---------------------------|---------------|-----------------------|------------------|
| -40°C to 125°C | SOP – D | Tape and reel | TLC3702QDRQ1 | 3702Q1 |
| | TSSOP – PW | Tape and reel | TLC3702QPWRQ1 | 3702Q1 |

- (1) For the most current package and ordering information, see the Package Option Addendum at the end of this document, or see the TI web site at <http://www.ti.com>.
- (2) Package drawings, thermal data, and symbolization are available at <http://www.ti.com/packaging>.



Please be aware that an important notice concerning availability, standard warranty, and use in critical applications of Texas Instruments semiconductor products and disclaimers thereto appears at the end of this data sheet.

LinCMOS, Advanced LinCMOS are trademarks of Texas Instruments.

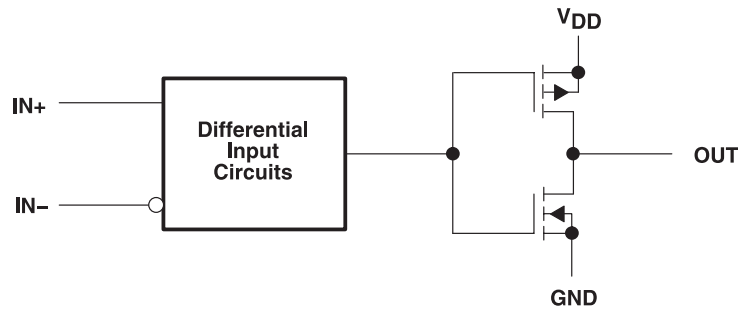
FUNCTIONAL BLOCK DIAGRAM (EACH COMPARATOR)

ABSOLUTE MAXIMUM RATINGS

 over operating free-air temperature range (unless otherwise noted) ⁽¹⁾

| | VALUE | UNIT |
|--|--------------------|--------------------|
| Supply voltage range, V_{DD} ⁽²⁾ | -0.3 V to 18 V | V |
| Differential input voltage, V_{ID} ⁽³⁾ | ± 18 | V |
| Input voltage range, V_I | -0.3 V to V_{DD} | V |
| Output voltage range, V_O | -0.3 V to V_{DD} | V |
| Input current, I_I | ± 5 | mA |
| Output current, I_O (each output) | ± 20 | mA |
| Total supply current into V_{DD} | 40 | mA |
| Total current out of GND | 40 | mA |
| Continuous total power dissipation | See Thermal Table | |
| Operating free-air temperature range, T_A | -40 to 125 | $^{\circ}\text{C}$ |
| Storage temperature range, T_{stg} | -65 to 150 | $^{\circ}\text{C}$ |
| Lead temperature 1,6 mm (1/16 inch) from case for 10 seconds | D package | 260 |
| | PW package | 260 |

- (1) Stresses beyond those listed under "absolute maximum ratings" may cause permanent damage to the device. These are stress ratings only, and functional operation of the device at these or any other conditions beyond those indicated under "recommended operating conditions" is not implied. Exposure to absolute-maximum-rated conditions for extended periods may affect device reliability.
- (2) All voltage values, except differential voltages, are with respect to GND.
- (3) Differential voltages are at IN+ with respect to IN-.

THERMAL INFORMATION

| THERMAL METRIC ⁽¹⁾ | | TLV3701SDBVRC | UNITS |
|-------------------------------|--|---------------|-----------------------------|
| | | DBV (5 PINS) | |
| θ_{JA} | Junction-to-ambient thermal resistance | 190.3 | $^{\circ}\text{C}/\text{W}$ |
| θ_{JcTop} | Junction-to-case (top) thermal resistance | 76.2 | |
| θ_{JB} | Junction-to-board thermal resistance | 49.6 | |
| ψ_{JT} | Junction-to-top characterization parameter | 3.7 | |
| ψ_{JB} | Junction-to-board characterization parameter | 49.1 | |
| θ_{JcBot} | Junction-to-case (bottom) thermal resistance | N/A | |

- (1) For more information about traditional and new thermal metrics, see the *IC Package Thermal Metrics* application report, [SPRA953](#).

RECOMMENDED OPERATING CONDITIONS

| | MIN | NOM | MAX | UNIT |
|------------------------------------|-----|-----|----------------|------|
| V_{DD} Supply voltage | 4 | 5 | 16 | V |
| V_{IC} Common-mode input voltage | 0 | | $V_{DD} - 1.5$ | V |
| I_{OH} High-level output current | | | -20 | mA |
| I_{OL} Low-level output current | | | 20 | mA |

RECOMMENDED OPERATING CONDITIONS (continued)

| | | MIN | NOM | MAX | UNIT |
|-------|--------------------------------|-----|-----|-----|------|
| T_A | Operating free-air temperature | -40 | | 125 | °C |

ELECTRICAL CHARACTERISTICS⁽¹⁾

 at specified operating free-air temperature range, $V_{DD} = 5\text{ V}$ (unless otherwise noted)

| PARAMETER | | TEST CONDITIONS | T_A | MIN | TYP | MAX | UNIT |
|-----------|-----------------------------------|---|----------------|---------------------|-----|-----|------|
| V_{IO} | Input offset voltage | $V_{DD} = 5\text{ V to } 10\text{ V}$, $V_{IC} = V_{ICRmin}$, See ⁽²⁾ | 25°C | | 1.2 | 5 | mV |
| | | | -40°C to 125°C | | | 10 | |
| I_{IO} | Input offset current | $V_{IC} = 2.5\text{ V}$ | 25°C | | 1 | | pA |
| | | | 125°C | | | 15 | |
| I_{IB} | Input bias current | $V_{IC} = 2.5\text{ V}$ | 25°C | | 5 | | dB |
| | | | 125°C | | | 30 | |
| V_{ICR} | Common-mode input voltage range | | 25°C | 0 to $V_{DD} - 1$ | | | V |
| | | | -40°C to 125°C | 0 to $V_{DD} - 1.5$ | | | |
| CMRR | Common-mode rejection ratio | $V_{IC} = V_{ICRmin}$ | 25°C | | 84 | | dB |
| | | | 125°C | | 83 | | |
| | | | -40°C | | 82 | | |
| k_{SVR} | Supply-voltage rejection ratio | $V_{DD} = 5\text{ V to } 10\text{ V}$ | 25°C | | 85 | | dB |
| | | | 125°C | | 85 | | |
| | | | -40°C | | 82 | | |
| V_{OH} | High-level output voltage | $V_{ID} = 1\text{ V}$, $I_{OH} = -4\text{ mA}$ | 25°C | 4.5 | | | V |
| | | | 125°C | 4.2 | | | |
| V_{OL} | Low-level output voltage | $V_{ID} = 1\text{ V}$, $I_{OH} = -4\text{ mA}$ | 25°C | | 210 | 300 | mV |
| | | | 125°C | | | 500 | |
| I_{DD} | Supply current (both comparators) | Outputs low, No load | 25°C | | 19 | 40 | μA |
| | | | -40°C to 125°C | | | 90 | |

(1) All characteristics are measured with zero common-mode voltage unless otherwise noted.

(2) The offset voltage limits given are the maximum values required to drive the output up to 4.5 V or down to 0.3 V.

SWITCHING CHARACTERISTICS

 at recommended operating conditions, $V_{DD} = 5\text{ V}$, $T_A = 25^\circ\text{C}$ (unless otherwise noted)

| PARAMETER | | TEST CONDITIONS | MIN | TYP | MAX | UNIT |
|-------------|--|---|-------------------|------|-----|------|
| $t_{(PLH)}$ | Propagation response time, low-to-high-level output ⁽¹⁾ | $f = 10\text{ kHz}$, $C_L = 50\text{ pF}$ | Overdrive = 2 mV | 4.5 | | μs |
| | | | Overdrive = 5 mV | 2.7 | | |
| | | | Overdrive = 10 mV | 1.9 | | |
| | | | Overdrive = 20 mV | 1.4 | | |
| | | | Overdrive = 40 mV | 1.1 | | |
| | | $V_I = 1.4\text{ V step at } IN+$ | | 1.1 | | |
| $t_{(PHL)}$ | Propagation response time, high-to-low-level output ⁽¹⁾ | $f = 10\text{ kHz}$, $C_L = 50\text{ pF}$ | Overdrive = 2 mV | 4 | | μs |
| | | | Overdrive = 5 mV | 2.3 | | |
| | | | Overdrive = 10 mV | 1.5 | | |
| | | | Overdrive = 20 mV | 0.95 | | |
| | | | Overdrive = 40 mV | 0.65 | | |
| | | $V_I = 1.4\text{ V step at } IN+$ | | 0.15 | | |
| t_f | Fall time | $f = 10\text{ kHz}$, $C_L = 50\text{ pF}$ | Overdrive = 50 mV | 50 | | ns |
| t_r | Rise time | $f = 10\text{ kHz}$, $C_L = 50\text{ pF}$ | Overdrive = 50 mV | 125 | | ns |

(1) Simultaneous switching of inputs causes degradation in output response..

PRINCIPLES OF OPERATION

LinCMOS™ Process

The LinCMOS™ process is a linear polysilicon-gate CMOS process. Primarily designed for single-supply applications, LinCMOS™ products facilitate the design of a wide range of high-performance analog functions from operational amplifiers to complex mixed-mode converters.

While digital designers are experienced with CMOS, MOS technologies are relatively new for analog designers. This short guide is intended to answer the most frequently asked questions related to the quality and reliability of LinCMOS™ products. Further questions should be directed to the nearest TI field sales office.

Electrostatic Discharge

CMOS circuits are prone to gate oxide breakdown when exposed to high voltages even if the exposure is only for very short periods of time. Electrostatic discharge (ESD) is one of the most common causes of damage to CMOS devices. It can occur when a device is handled without proper consideration for environmental electrostatic charges, e.g., during board assembly. If a circuit in which one amplifier from a dual op amp is being used and the unused pins are left open, high voltages tend to develop. If there is no provision for ESD protection, these voltages may eventually punch through the gate oxide and cause the device to fail. To prevent voltage buildup, each pin is protected by internal circuitry.

Standard ESD-protection circuits safely shunt the ESD current by providing a mechanism whereby one or more transistors break down at voltages higher than the normal operating voltages but lower than the breakdown voltage of the input gate. This type of protection scheme is limited by leakage currents which flow through the shunting transistors during normal operation after an ESD voltage has occurred. Although these currents are small, on the order of tens of nanoamps, CMOS amplifiers are often specified to draw input currents as low as tens of picoamps.

To overcome this limitation, TI design engineers developed the patented ESD-protection circuit shown in Figure 1. This circuit can withstand several successive 2-kV ESD pulses, while reducing or eliminating leakage currents that may be drawn through the input pins. A more detailed discussion of the operation of the TI ESD-protection circuit is presented in the following sections.

All input and output pins on LinCMOS™ and Advanced LinCMOS™ products have associated ESD-protection circuitry that undergoes qualification testing to withstand 2000 V discharged from a 100-pF capacitor through a 1500-Ω resistor (human body model) and 200 V from a 100-pF capacitor with no current-limiting resistor (charged device model). These tests simulate both operator and machine handling of devices during normal test and assembly operations.

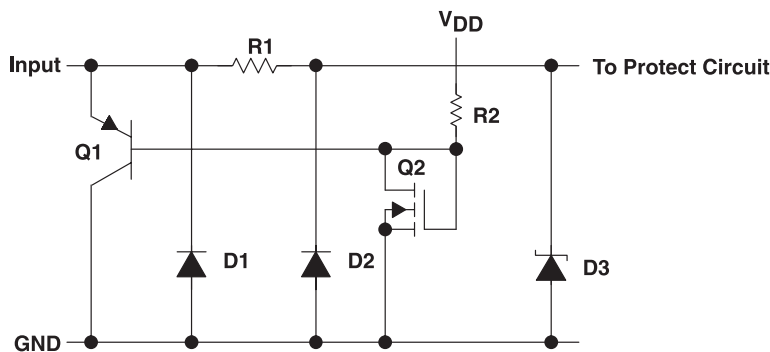

Figure 1. LinCMOS™ ESD-Protection Schematic

Input Protection Circuit Operation

Texas Instruments patented protection circuitry allows for both positive- and negative-going ESD transients. These transients are characterized by extremely fast rise times and usually low energies, and can occur both when the device has all pins open and when it is installed in a circuit.

Positive ESD Transients

Initial positive charged energy is shunted through Q1 to V_{SS} . Q1 turns on when the voltage at the input rises above the voltage on the V_{DD} pin by a value equal to the V_{BE} of Q1. The base current increases through R2 with input current as Q1 saturates. The base current through R2 forces the voltage at the drain and gate of Q2 to exceed its threshold level ($V_T \sim 22$ to 26 V) and turn Q2 on. The shunted input current through Q1 to V_{SS} is now shunted through the n-channel enhancement-type MOSFET Q2 to V_{SS} . If the voltage on the input pin continues to rise, the breakdown voltage of the zener diode D3 is exceeded and all remaining energy is dissipated in R1 and D3. The breakdown voltage of D3 is designed to be 24 V to 27 V, which is well below the gate-oxide voltage of the circuit to be protected.

Negative ESD Transients

The negative charged ESD transients are shunted directly through D1. Additional energy is dissipated in R1 and D2 as D2 becomes forward biased. The voltage seen by the protected circuit is -0.3 V to -1 V (the forward voltage of D1 and D2).

Circuit-Design Considerations

LinCMOS™ products are being used in actual circuit environments that have input voltages that exceed the recommended common-mode input voltage range and activate the input protection circuit. Even under normal operation, these conditions occur during circuit power up or power down, and in many cases, when the device is being used for a signal conditioning function. The input voltages can exceed V_{ICR} and not damage the device only if the inputs are current limited. The recommended current limit shown on most product data sheets is ± 5 mA. [Figure 2](#) and [Figure 3](#) show typical characteristics for input voltage versus input current.

Normal operation and correct output state can be expected even when the input voltage exceeds the positive supply voltage. Again, the input current should be externally limited even though internal positive current limiting is achieved in the input protection circuit by the action of Q1. When Q1 is on, it saturates and limits the current to approximately 5-mA collector current by design. When saturated, Q1 base current increases with input current. This base current is forced into the V_{DD} pin and into the device I_{DD} or the V_{DD} supply through R2 producing the current limiting effects shown in [Figure 2](#). This internal limiting lasts only as long as the input voltage is below the V_T of Q2.

When the input voltage exceeds the negative supply voltage, normal operation is affected and output voltage states may not be correct. Also, the isolation between channels of multiple devices (duals and quads) can be severely affected. External current limiting must be used since this current is directly shunted by D1 and D2 and no internal limiting is achieved. If normal output voltage states are required, an external input voltage clamp is required (see [Figure 4](#)).

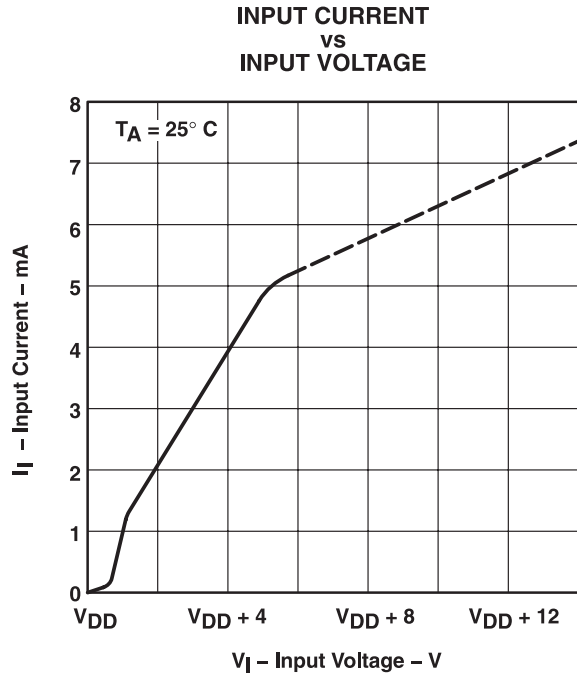

Figure 2.

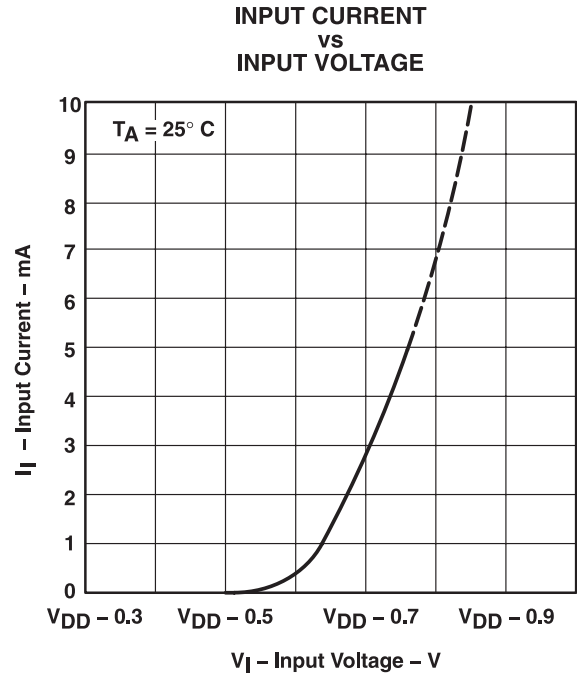
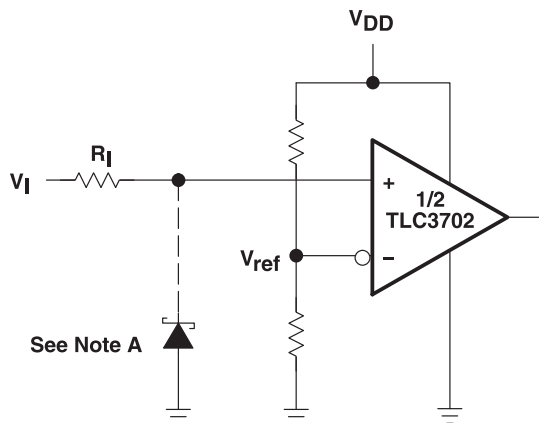

Figure 3.



Positive Voltage Input Current Limit :

$$R_I = \frac{V_I - V_{DD} - 0.3\text{ V}}{5\text{ mA}}$$

Negative Voltage Input Current Limit :

$$R_I = \frac{-V_I - V_{DD} - (-0.3\text{ V})}{5\text{ mA}}$$

- A. If the correct input state is required when the negative input exceeds GND, a Schottky clamp is required.

Figure 4. Typical Input Current-Limiting Configuration for a LinCMOS™ Comparator

PARAMETER MEASUREMENT INFORMATION

The TLC3702 contains a digital output stage which, if held in the linear region of the transfer curve, can cause damage to the device. Conventional operational amplifier/comparator testing incorporates the use of a servo loop which is designed to force the device output to a level within this linear region. Since the servo-loop method of testing cannot be used, we offer the following alternatives for measuring parameters such as input offset voltage, common-mode rejection, etc.

To verify that the input offset voltage falls within the limits specified, the limit value is applied to the input as shown in Figure 5(a). With the noninverting input positive with respect to the inverting input, the output should be high. With the input polarity reversed, the output should be low.

A similar test can be made to verify the input offset voltage at the common-mode extremes. The supply voltages can be slewed to provide greater accuracy, as shown in Figure 5(b) for the V_{ICR} test. This slewing is done instead of changing the input voltages.

A close approximation of the input offset voltage can be obtained by using a binary search method to vary the differential input voltage while monitoring the output state. When the applied input voltage differential is equal, but opposite in polarity, to the input offset voltage, the output changes states.

Figure 6 illustrates a practical circuit for direct dc measurement of input offset voltage that does not bias the comparator in the linear region. The circuit consists of a switching mode servo loop in which IC1a generates a triangular waveform of approximately 20-mV amplitude. IC1b acts as a buffer, with C2 and R4 removing any residual dc offset. The signal is then applied to the inverting input of the comparator under test, while the noninverting input is driven by the output of the integrator formed by IC1c through the voltage divider formed by R8 and R9. The loop reaches a stable operating point when the output of the comparator under test has a duty cycle of exactly 50%, which can only occur when the incoming triangle wave is sliced symmetrically or when the voltage at the noninverting input exactly equals the input offset voltage.

Voltage dividers R8 and R9 provide an increase in input offset voltage by a factor of 100 to make measurement easier. The values of R5, R7, R8, and R9 can significantly influence the accuracy of the reading; therefore, it is suggested that their tolerance level be one percent or lower.

Measuring the extremely low values of input current requires isolation from all other sources of leakage current and compensation for the leakage of the test socket and board. With a good picoammeter, the socket and board leakage can be measured with no device in the socket. Subsequently, this open socket leakage value can be subtracted from the measurement obtained with a device in the socket to obtain the actual input current of the device.

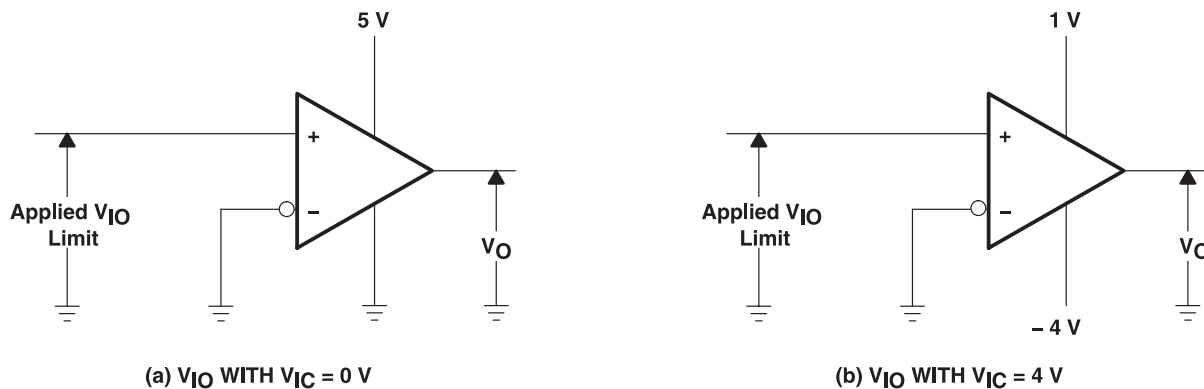
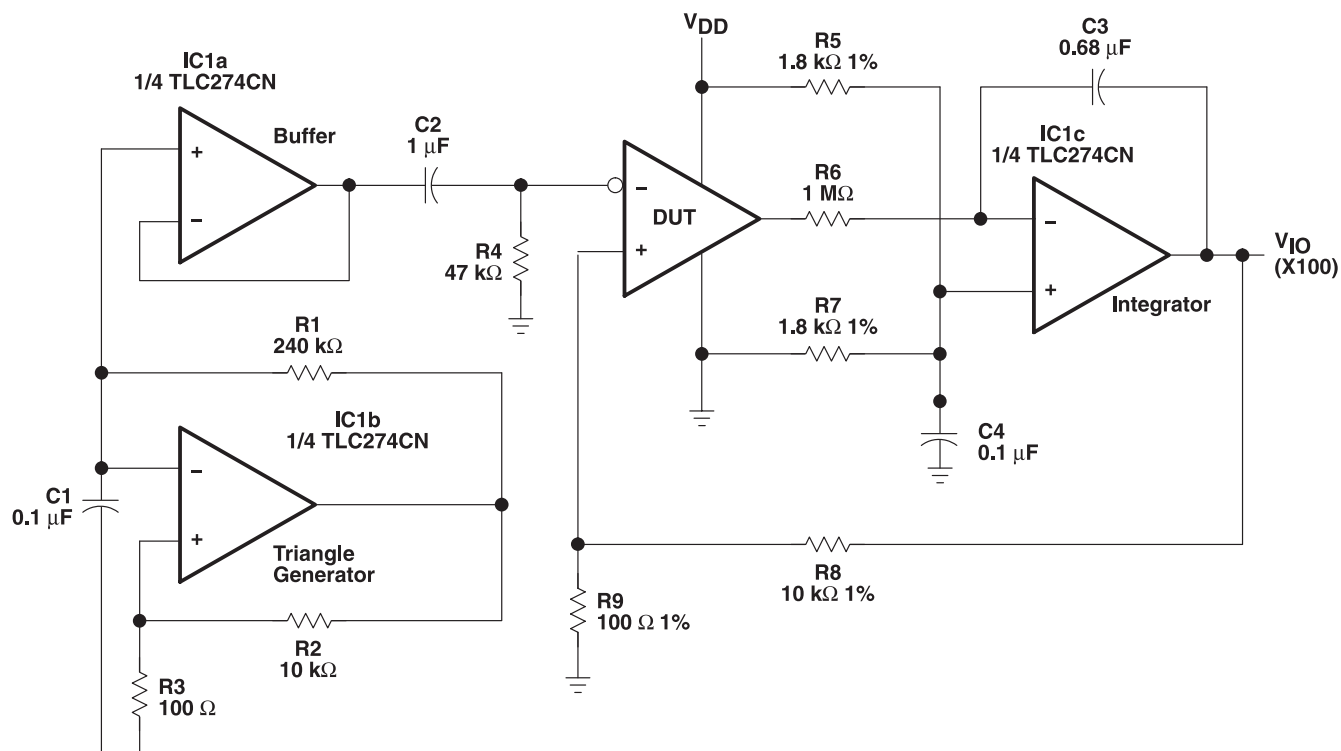
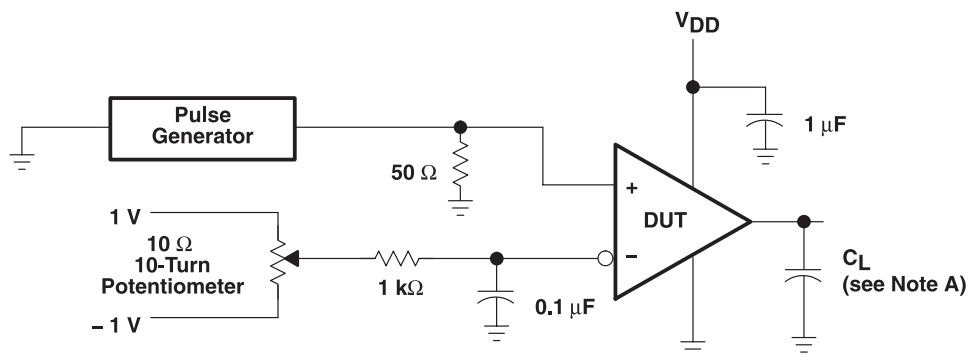

Figure 5. Method for Verifying That Input Offset Voltage Is Within Specified Limits

PARAMETER MEASUREMENT INFORMATION (continued)

Figure 6. Circuit for Input Offset Voltage Measurement

Response time is defined as the interval between the application of an input step function and the instant when the output reaches 50% of its maximum value. Response time for the low-to-high-level output is measured from the leading edge of the input pulse, while response time for the high-to-low-level output is measured from the trailing edge of the input pulse. Response time measurement at low input signal levels can be greatly affected by the input offset voltage. The offset voltage should be balanced by the adjustment at the inverting input as shown in Figure 7, so that the circuit is just at the transition point. A low signal, for example 105-mV or 5-mV overdrive, causes the output to change state

PARAMETER MEASUREMENT INFORMATION (continued)

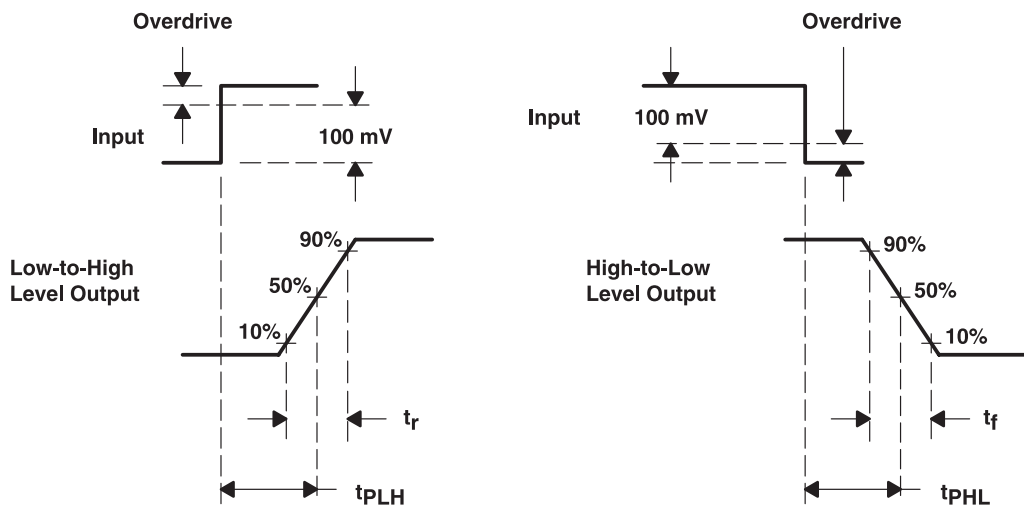

TEST CIRCUIT



VOLTAGE WAVEFORMS

NOTE A: CL includes probe and jig capacitance.

Figure 7. Response, Rise, and Fall Times Circuit and Voltage Waveforms

TYPICAL CHARACTERISTICS

Table of Graphs

| | | | FIGURE |
|-----------|---|---|-----------|
| V_{IO} | Input offset voltage | Distribution | Figure 8 |
| I_{IB} | Input bias current | vs Free-air temperature | Figure 9 |
| CMRR | Common-mode rejection ratio | vs Free-air temperature | Figure 10 |
| k_{SVR} | Supply-voltage rejection ratio | vs Free-air temperature | Figure 11 |
| V_{OH} | High-level output current | vs Free-air temperature | Figure 12 |
| | | vs High-level output current | Figure 13 |
| V_{OL} | Low-level output voltage | vs Low-level output current | Figure 14 |
| | | vs Free-air temperature | Figure 15 |
| t_t | Transition time | vs Load capacitance | Figure 16 |
| | Supply current response | vs Time | Figure 17 |
| | Low-to-high-level output response | Low-to-high level output propagation delay time | Figure 18 |
| | High-to-low level output response | High-to-low level output propagation delay time | Figure 19 |
| t_{PLH} | Low-to-high level output propagation delay time | vs Supply voltage | Figure 20 |
| t_{PHL} | High-to-low level output propagation delay time | vs Supply voltage | Figure 21 |
| | | vs Frequency | Figure 22 |
| I_{DD} | Supply current | vs Supply voltage | Figure 23 |
| | | vs Free-air temperature | Figure 24 |

Data at high and low temperatures are applicable only within the rated operating free-air temperature ranges of the device.

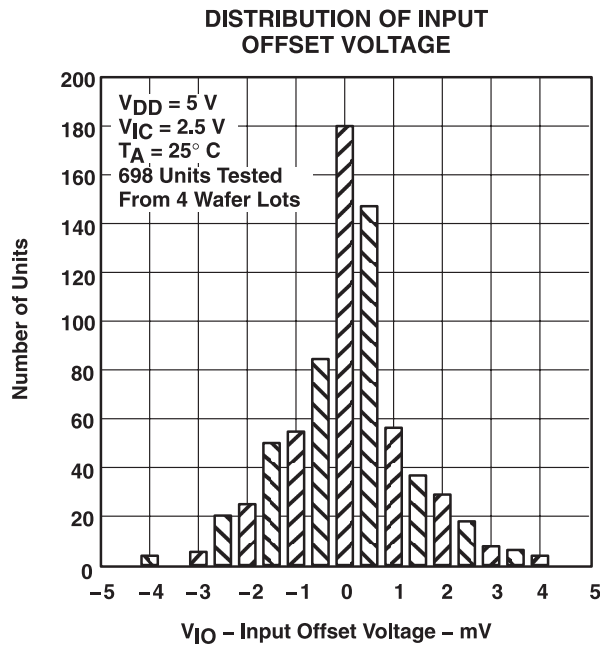

Figure 8.

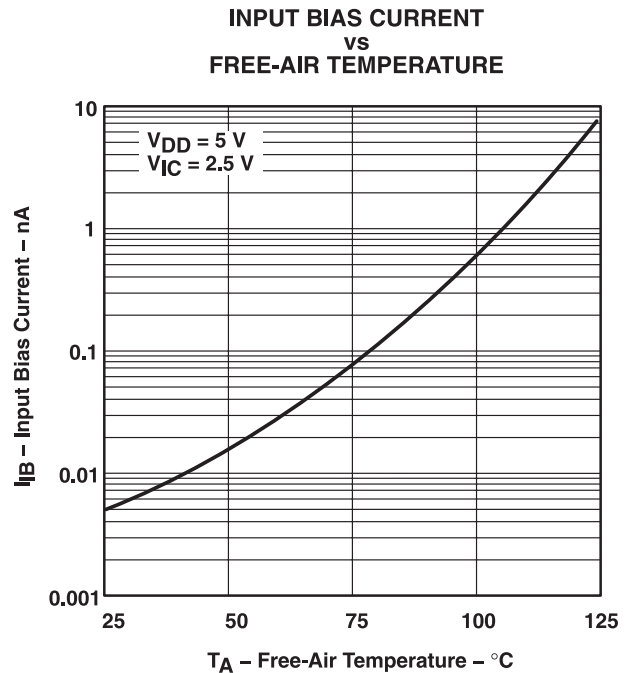

Figure 9.

Data at high and low temperatures are applicable only within the rated operating free-air temperature ranges of the device.

**COMMON-MODE REJECTION RATIO
vs
FREE-AIR TEMPERATURE**

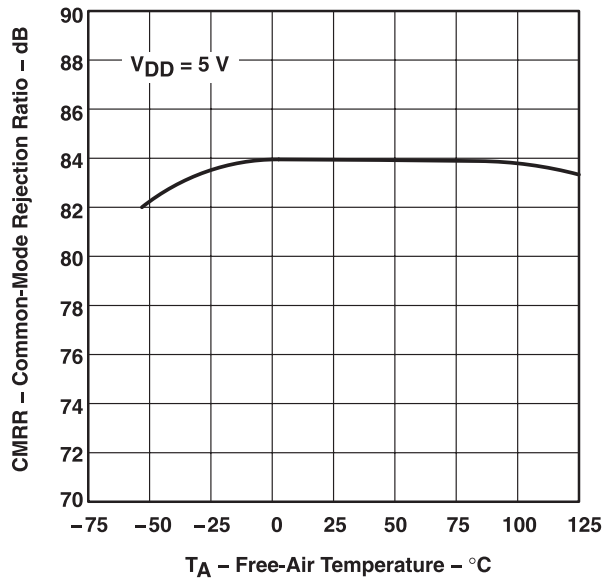

Figure 10.

**SUPPLY VOLTAGE REJECTION RATIO
vs
FREE-AIR TEMPERATURE**

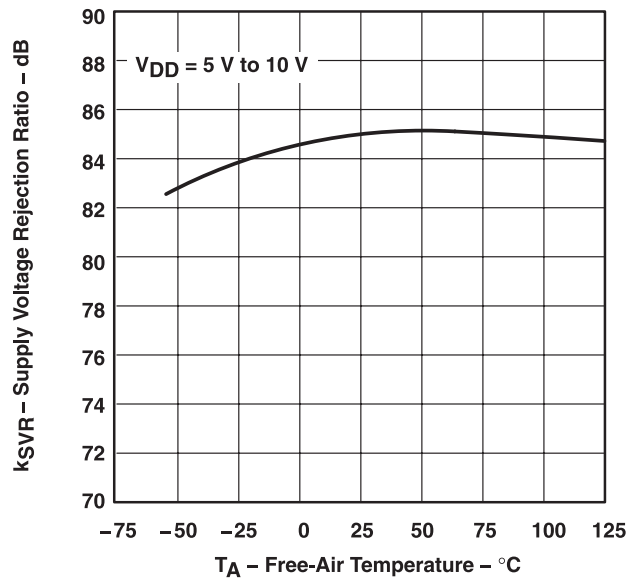

Figure 11.

**HIGH-LEVEL OUTPUT VOLTAGE
vs
FREE-AIR TEMPERATURE**

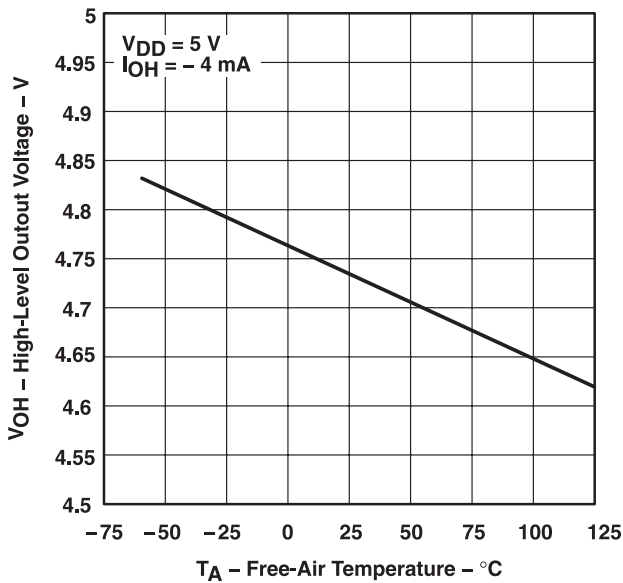

Figure 12.

**HIGH-LEVEL OUTPUT VOLTAGE
vs
HIGH-LEVEL OUTPUT CURRENT**

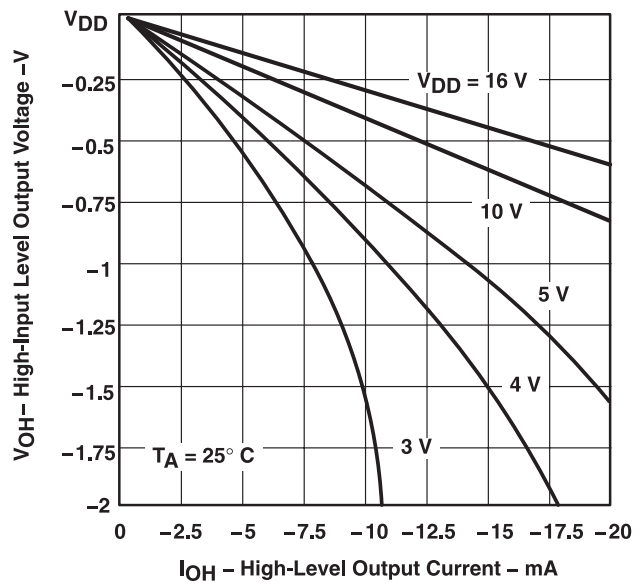

Figure 13.

TLC3702-Q1

SGLS156 C – MARCH 2003 – REVISED DECEMBER 2011

www.ti.com

Data at high and low temperatures are applicable only within the rated operating free-air temperature ranges of the device.

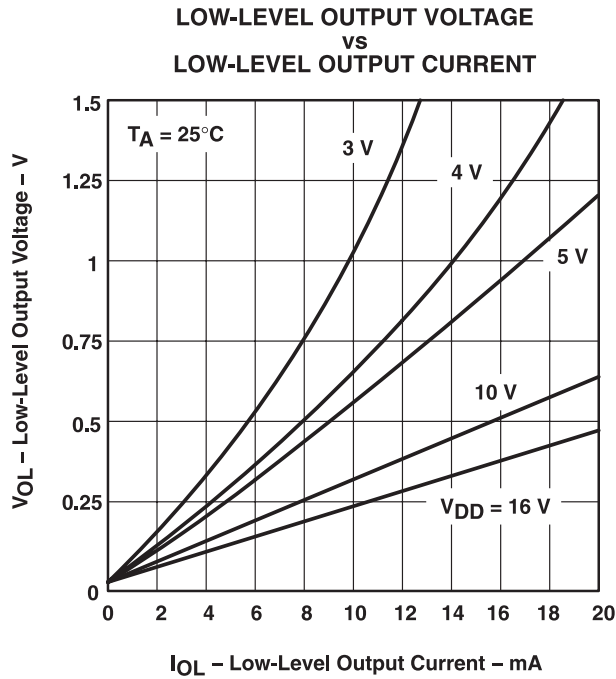

Figure 14.

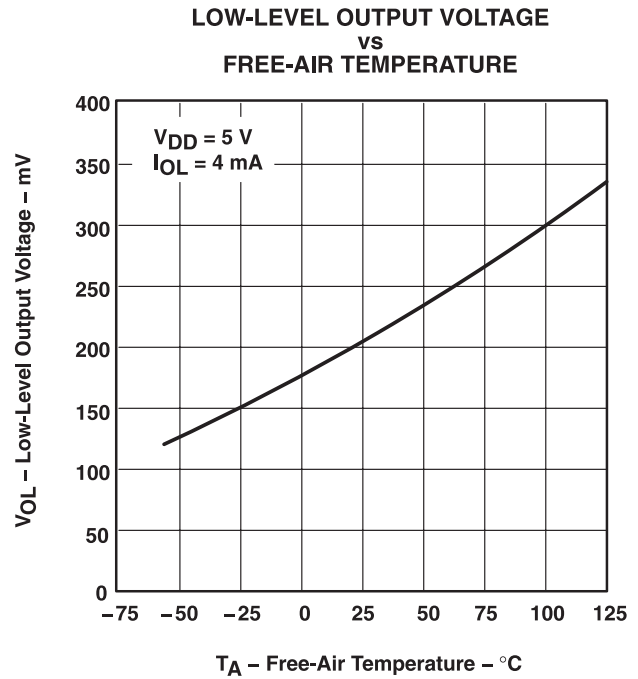

Figure 15.

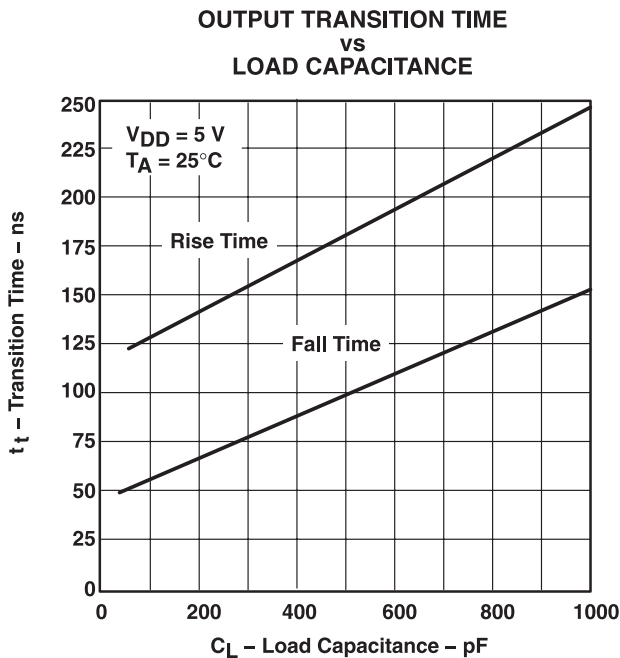

Figure 16.

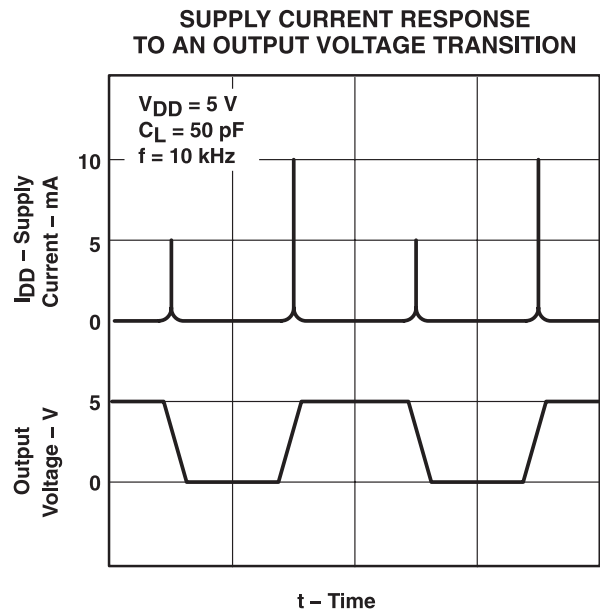

Figure 17.

Data at high and low temperatures are applicable only within the rated operating free-air temperature ranges of the device.

LOW-TO-HIGH-LEVEL OUTPUT RESPONSE FOR VARIOUS INPUT OVERDRIVES

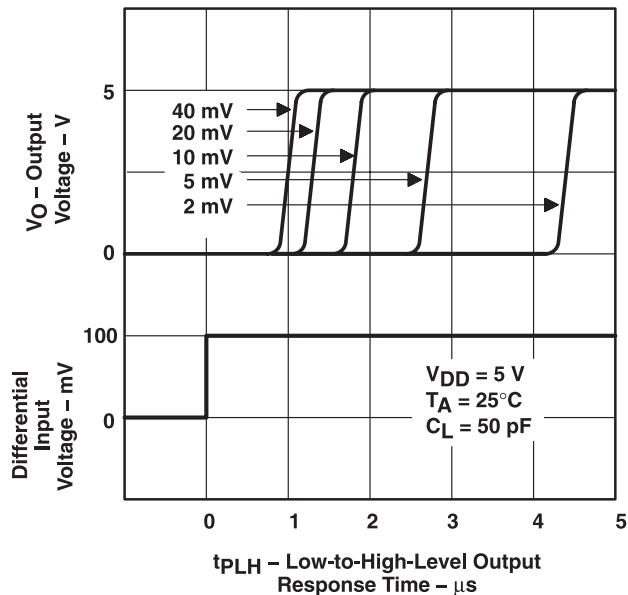

Figure 18.

HIGH-TO-LOW-LEVEL OUTPUT RESPONSE FOR VARIOUS INPUT OVERDRIVES

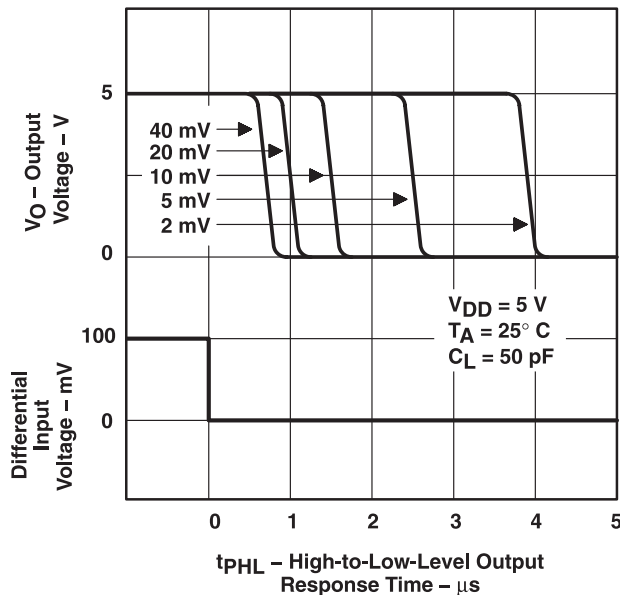

Figure 19.

LOW TO HIGH LEVEL OUTPUT RESPONSE TIME vs SUPPLY VOLTAGE

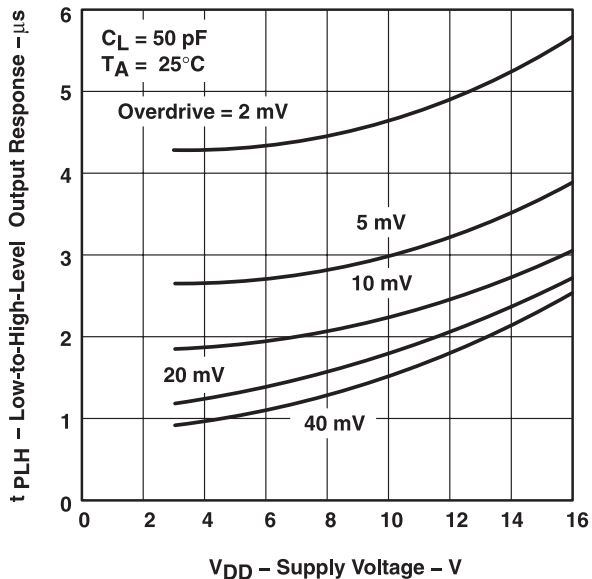

Figure 20.

HIGH-TO-LOW-LEVEL OUTPUT RESPONSE TIME vs SUPPLY VOLTAGE

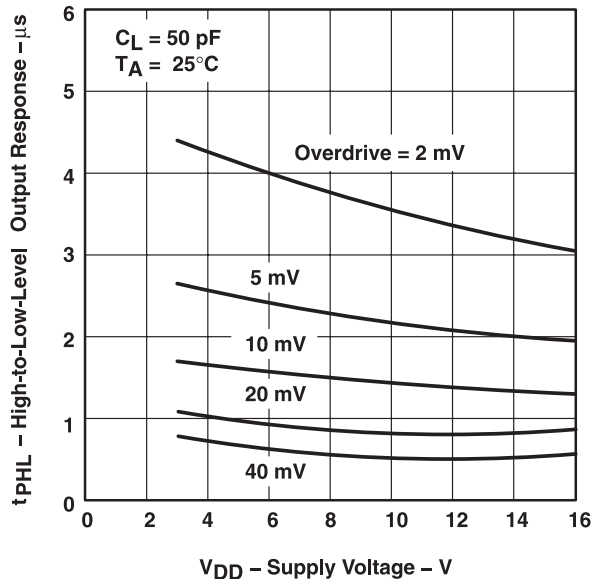

Figure 21.

TLC3702-Q1

SGLS156 C – MARCH 2003 – REVISED DECEMBER 2011

www.ti.com

Data at high and low temperatures are applicable only within the rated operating free-air temperature ranges of the device.

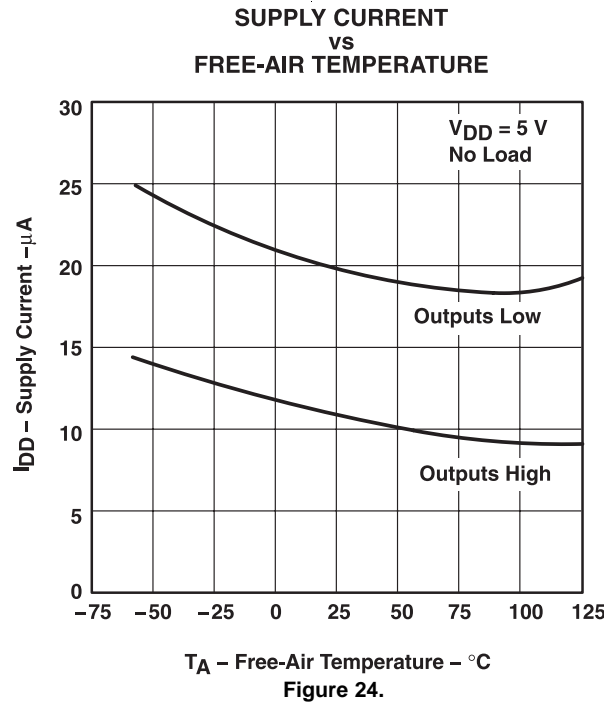
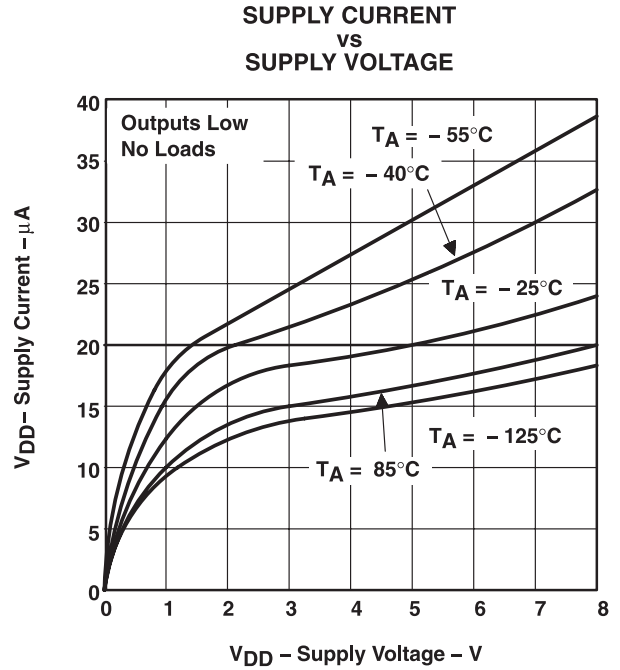
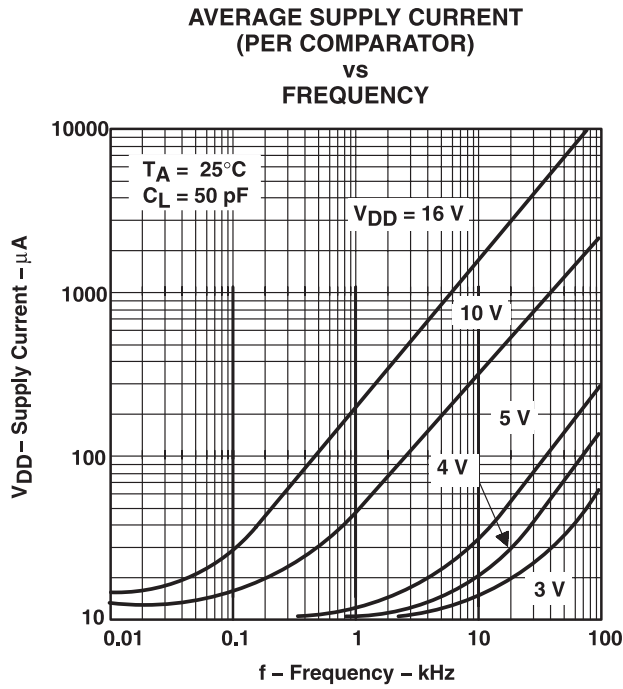

APPLICATION INFORMATION

The inputs should always remain within the supply rails in order to avoid forward biasing the diodes in the electrostatic discharge (ESD) protection structure. If either input exceeds this range, the device is not damaged as long as the input is limited to less than 5 mA. To maintain the expected output state, the inputs must remain within the common-mode range. For example, at 25°C with $V_{DD} = 5\text{ V}$, both inputs must remain between -0.2 V and 4 V to ensure proper device operation.

To ensure reliable operation, the supply should be decoupled with a capacitor ($0.1\text{ }\mu\text{F}$) that is positioned as close to the device as possible.

The TLC3702 has internal ESD-protection circuits that prevent functional failures at voltages up to 2000 V as tested under MIL-STD-883C, Method 3015.2; however, care should be exercised in handling these devices as exposure to ESD may result in the degradation of the device parametric performance.

Table 1. Applications

| | FIGURE |
|--|--------|
| Pulse-width-modulated motor speed controller | 25 |
| Enhanced supply supervisor | 26 |
| Two-phase nonoverlapping clock generator | 27 |
| Micropower switching regulator | 28 |

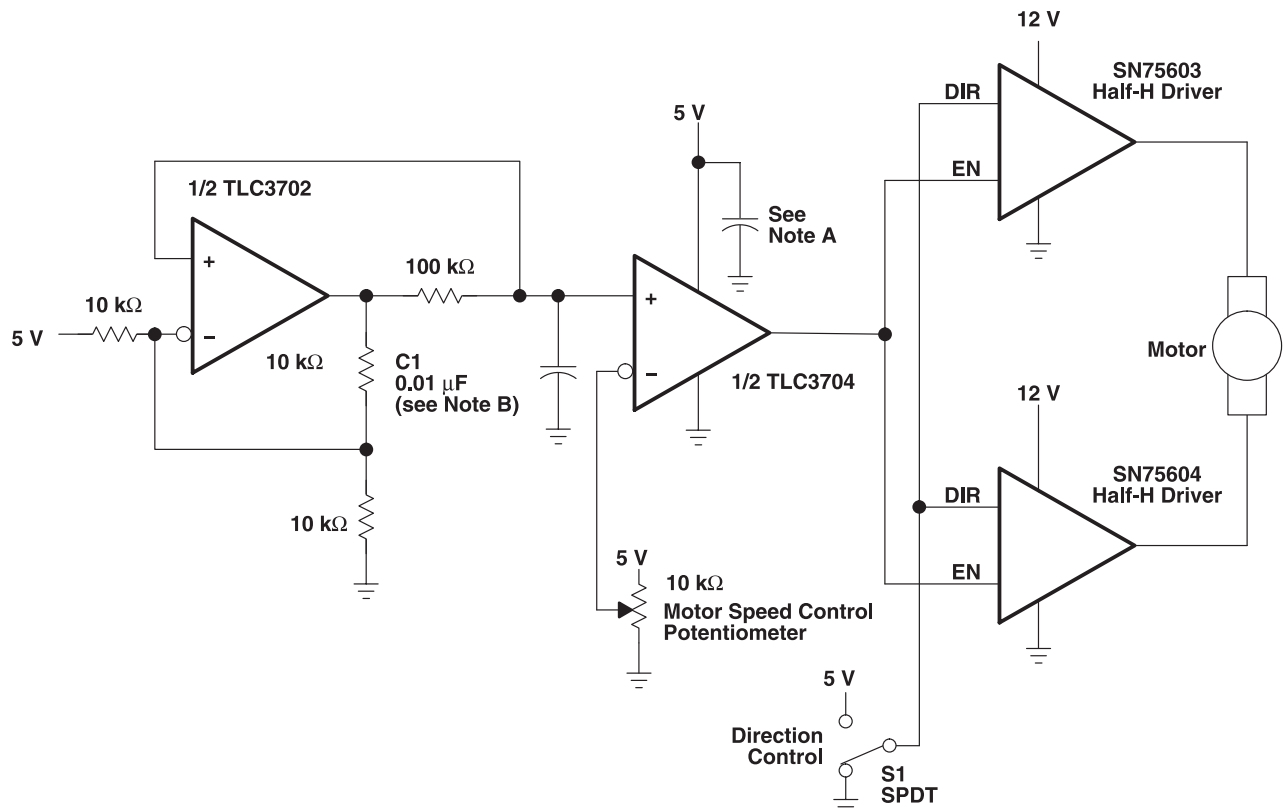

NOTES: A. The recommended minimum capacitance is $10\text{ }\mu\text{F}$ to eliminate common ground switching noise.
 B. Adjust C1 for change in oscillator frequency.

Figure 25. Pulse-Width-Modulated Motor Speed Controller

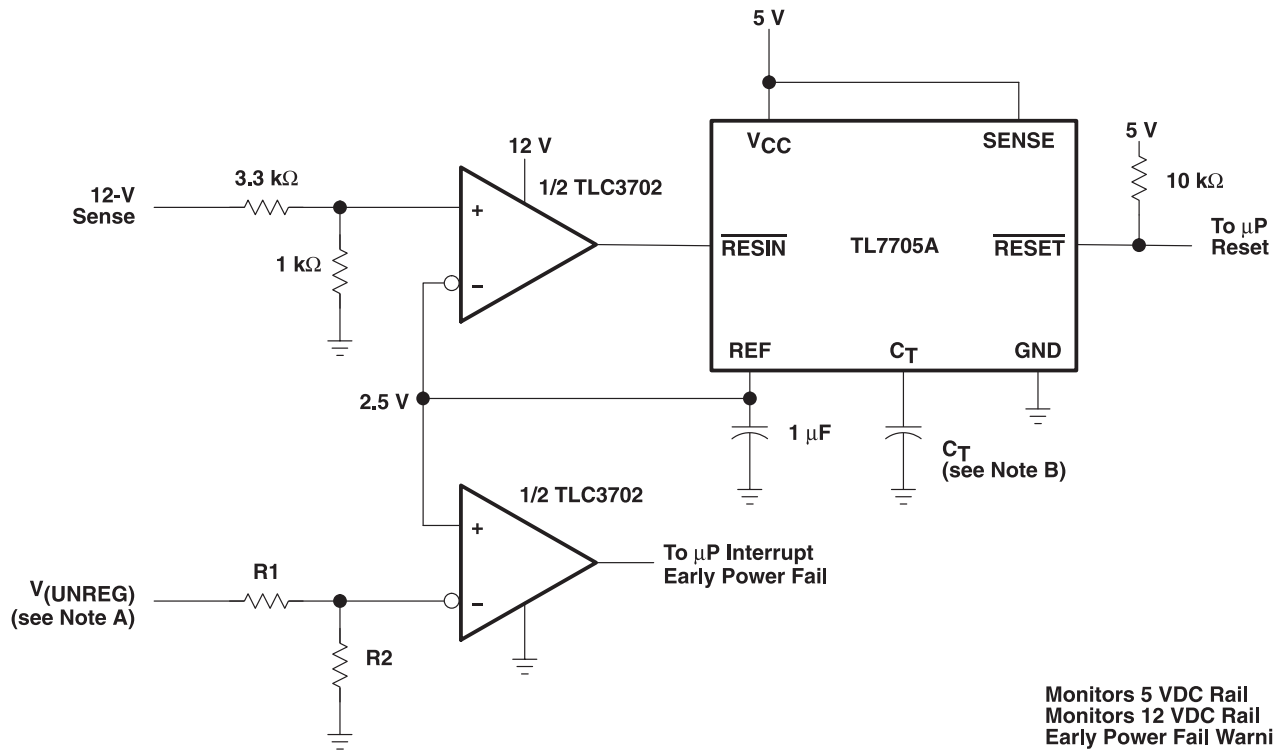

Monitors 5 VDC Rail
Monitors 12 VDC Rail
Early Power Fail Warning

- NOTES: A. $V_{(UNREG)} = 2.5 \frac{(R1 + R2)}{R2}$
 B. The value of C_T determines the time delay of reset.

Figure 26. Enhanced Supply Supervisor

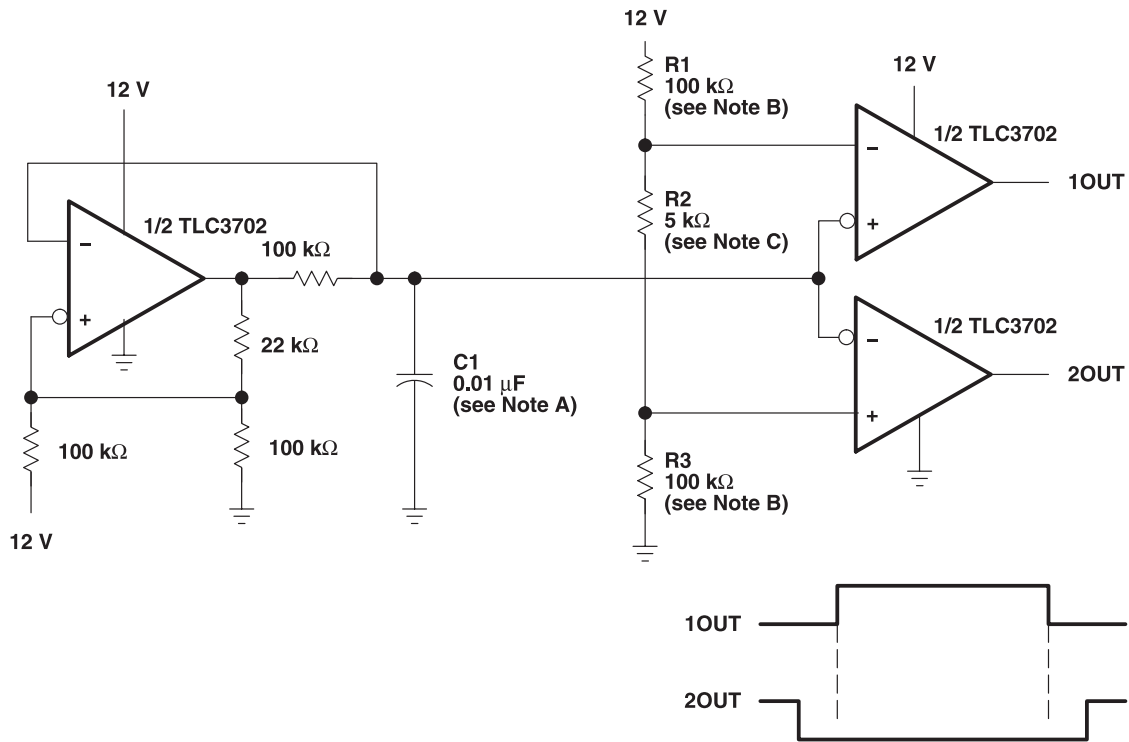

- NOTES: A. Adjust C1 for a change in oscillator frequency where:
 $1/f = 1.85(100\text{ k}\Omega)C1$
 B. Adjust R1 and R3 to change duty cycle
 C. Adjust R2 to change deadtime

Figure 27. Enhanced Supply Supervisor

TLC3702-Q1

SGLS156 C –MARCH 2003–REVISED DECEMBER 2011

www.ti.com

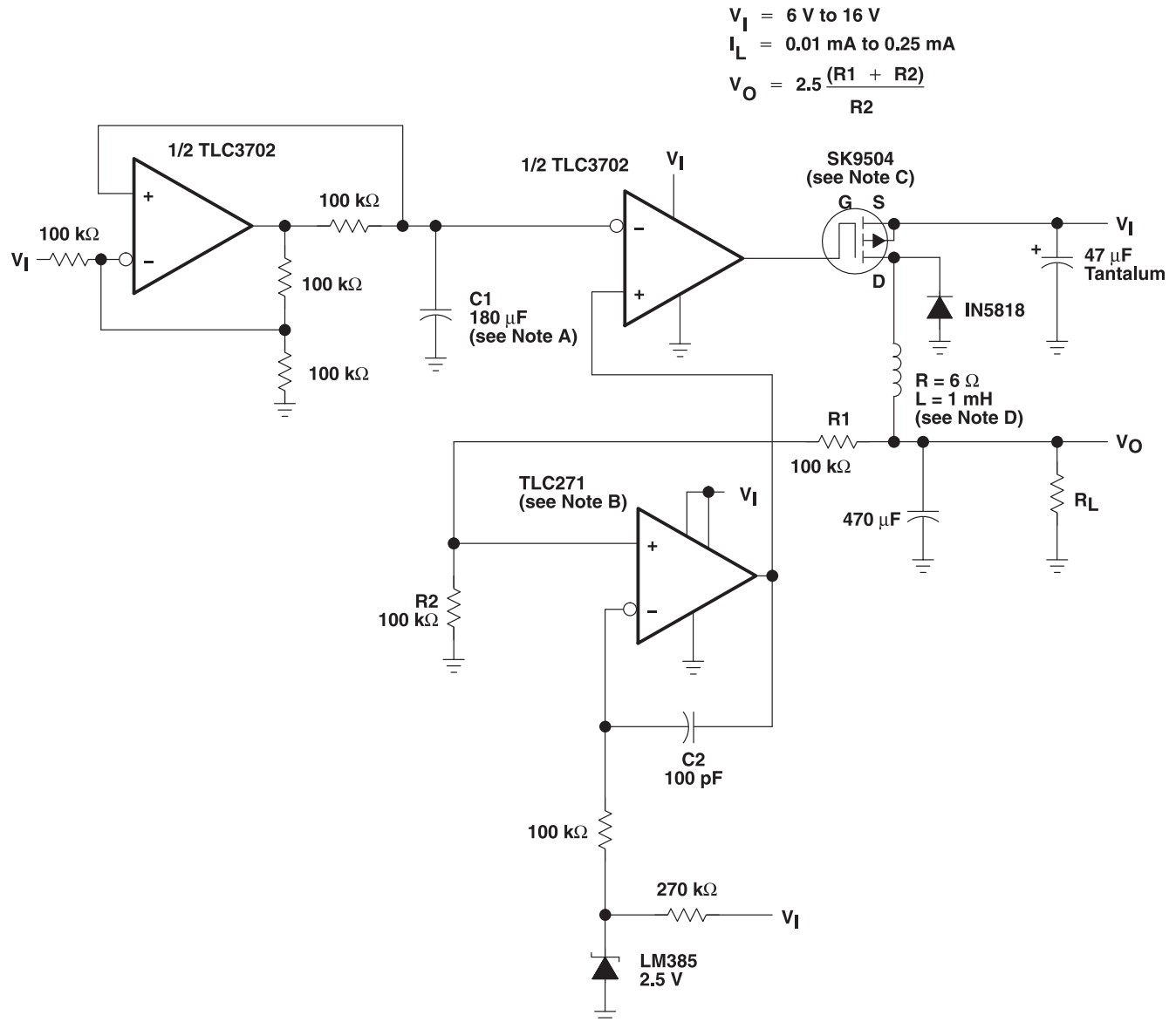

- NOTES:
- A. Adjust $C1$ for a change in oscillator frequency
 - B. TLC271 – Tie pin 8 to pin 7 for low bias operation
 - C. SK9504 – $V_{DS} = 40\text{ V}$
 $I_{DS} = 1\text{ A}$
 - D. To achieve microampere current drive, the inductance of the circuit must be increased.

Figure 28. Micropower Switching Regulator

PACKAGING INFORMATION

| Orderable Device | Status ⁽¹⁾ | Package Type | Package Drawing | Pins | Package Qty | Eco Plan ⁽²⁾ | Lead/ Ball Finish | MSL Peak Temp ⁽³⁾ | Samples (Requires Login) |
|------------------|-----------------------|--------------|-----------------|------|-------------|----------------------------|----------------------|------------------------------|-----------------------------|
| TLC3702QDRG4Q1 | ACTIVE | SOIC | D | 8 | 2500 | Green (RoHS & no Sb/Br) | CU NIPDAU | Level-1-260C-UNLIM | |
| TLC3702QDRQ1 | ACTIVE | SOIC | D | 8 | 2500 | Green (RoHS & no Sb/Br) | CU NIPDAU | Level-1-260C-UNLIM | |
| TLC3702QPWRQ1 | ACTIVE | TSSOP | PW | 8 | 2000 | Green (RoHS & no Sb/Br) | CU NIPDAU | Level-3-260C-168 HR | |

⁽¹⁾ The marketing status values are defined as follows:

ACTIVE: Product device recommended for new designs.

LIFEBUY: TI has announced that the device will be discontinued, and a lifetime-buy period is in effect.

NRND: Not recommended for new designs. Device is in production to support existing customers, but TI does not recommend using this part in a new design.

PREVIEW: Device has been announced but is not in production. Samples may or may not be available.

OBsolete: TI has discontinued the production of the device.

⁽²⁾ Eco Plan - The planned eco-friendly classification: Pb-Free (RoHS), Pb-Free (RoHS Exempt), or Green (RoHS & no Sb/Br) - please check <http://www.ti.com/productcontent> for the latest availability information and additional product content details.

TBD: The Pb-Free/Green conversion plan has not been defined.

Pb-Free (RoHS): TI's terms "Lead-Free" or "Pb-Free" mean semiconductor products that are compatible with the current RoHS requirements for all 6 substances, including the requirement that lead not exceed 0.1% by weight in homogeneous materials. Where designed to be soldered at high temperatures, TI Pb-Free products are suitable for use in specified lead-free processes.

Pb-Free (RoHS Exempt): This component has a RoHS exemption for either 1) lead-based flip-chip solder bumps used between the die and package, or 2) lead-based die adhesive used between the die and leadframe. The component is otherwise considered Pb-Free (RoHS compatible) as defined above.

Green (RoHS & no Sb/Br): TI defines "Green" to mean Pb-Free (RoHS compatible), and free of Bromine (Br) and Antimony (Sb) based flame retardants (Br or Sb do not exceed 0.1% by weight in homogeneous material)

⁽³⁾ MSL, Peak Temp. -- The Moisture Sensitivity Level rating according to the JEDEC industry standard classifications, and peak solder temperature.

Important Information and Disclaimer: The information provided on this page represents TI's knowledge and belief as of the date that it is provided. TI bases its knowledge and belief on information provided by third parties, and makes no representation or warranty as to the accuracy of such information. Efforts are underway to better integrate information from third parties. TI has taken and continues to take reasonable steps to provide representative and accurate information but may not have conducted destructive testing or chemical analysis on incoming materials and chemicals. TI and TI suppliers consider certain information to be proprietary, and thus CAS numbers and other limited information may not be available for release.

In no event shall TI's liability arising out of such information exceed the total purchase price of the TI part(s) at issue in this document sold by TI to Customer on an annual basis.

OTHER QUALIFIED VERSIONS OF TLC3702-Q1 :

- Catalog: [TLC3702](#)

- Enhanced Product: [TLC3702-EP](#)

- Military: [TLC3702M](#)

NOTE: Qualified Version Definitions:

- Catalog - TI's standard catalog product
- Enhanced Product - Supports Defense, Aerospace and Medical Applications
- Military - QML certified for Military and Defense Applications

TAPE AND REEL INFORMATION
REEL DIMENSIONS

TAPE DIMENSIONS

| | |
|----|---|
| A0 | Dimension designed to accommodate the component width |
| B0 | Dimension designed to accommodate the component length |
| K0 | Dimension designed to accommodate the component thickness |
| W | Overall width of the carrier tape |
| P1 | Pitch between successive cavity centers |

TAPE AND REEL INFORMATION

*All dimensions are nominal

| Device | Package Type | Package Drawing | Pins | SPQ | Reel Diameter (mm) | Reel Width W1 (mm) | A0 (mm) | B0 (mm) | K0 (mm) | P1 (mm) | W (mm) | Pin1 Quadrant |
|---------------|--------------|-----------------|------|------|--------------------|--------------------|---------|---------|---------|---------|--------|---------------|
| TLC3702QPWRQ1 | TSSOP | PW | 8 | 2000 | 330.0 | 12.4 | 7.0 | 3.6 | 1.6 | 8.0 | 12.0 | Q1 |

TAPE AND REEL BOX DIMENSIONS



*All dimensions are nominal

| Device | Package Type | Package Drawing | Pins | SPQ | Length (mm) | Width (mm) | Height (mm) |
|---------------|--------------|-----------------|------|------|-------------|------------|-------------|
| TLC3702QPWRQ1 | TSSOP | PW | 8 | 2000 | 346.0 | 346.0 | 29.0 |

D (R-PDSO-G8)

PLASTIC SMALL OUTLINE

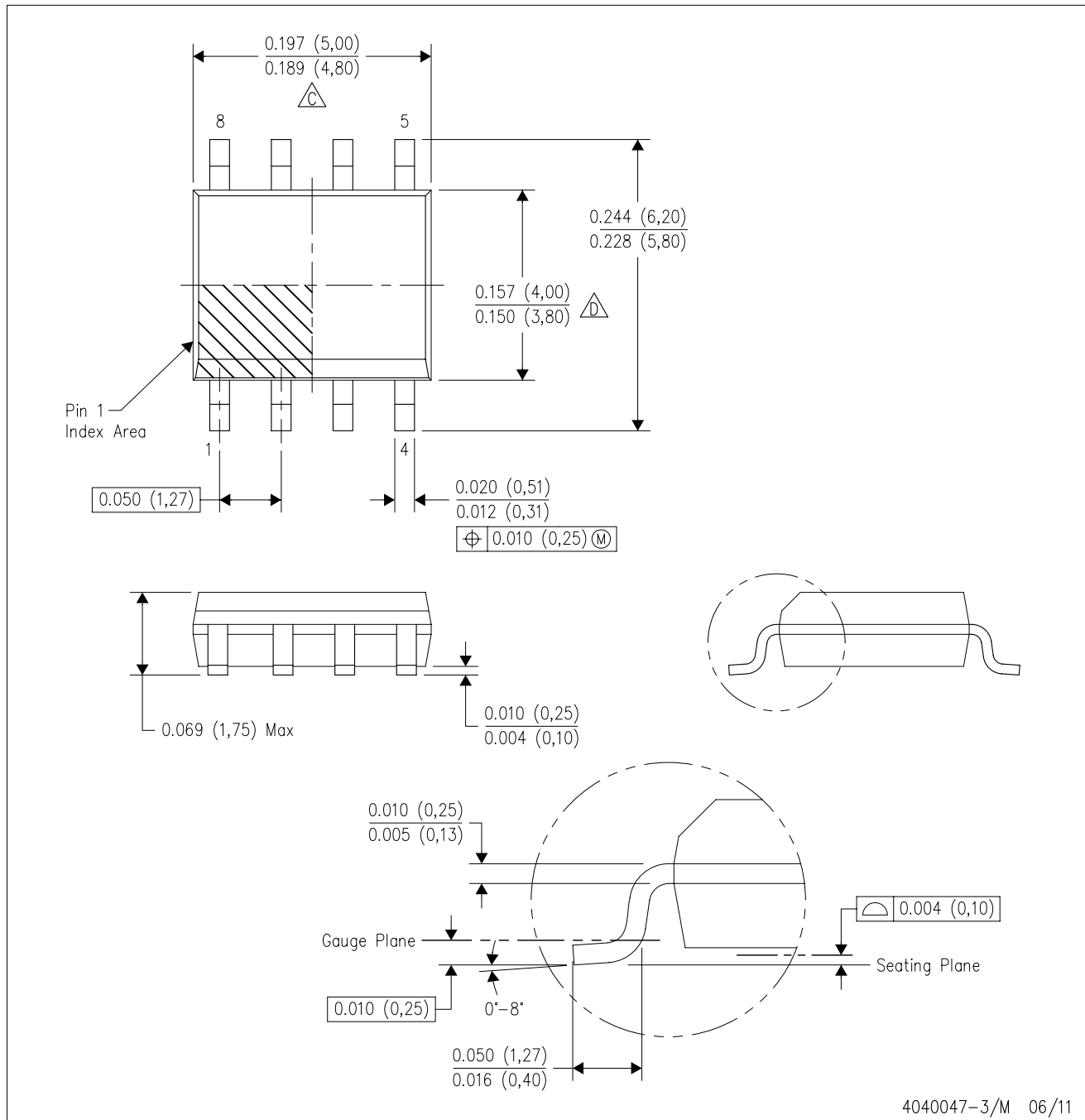

4040047-3/M 06/11

D (R-PDSO-G8)

PLASTIC SMALL OUTLINE

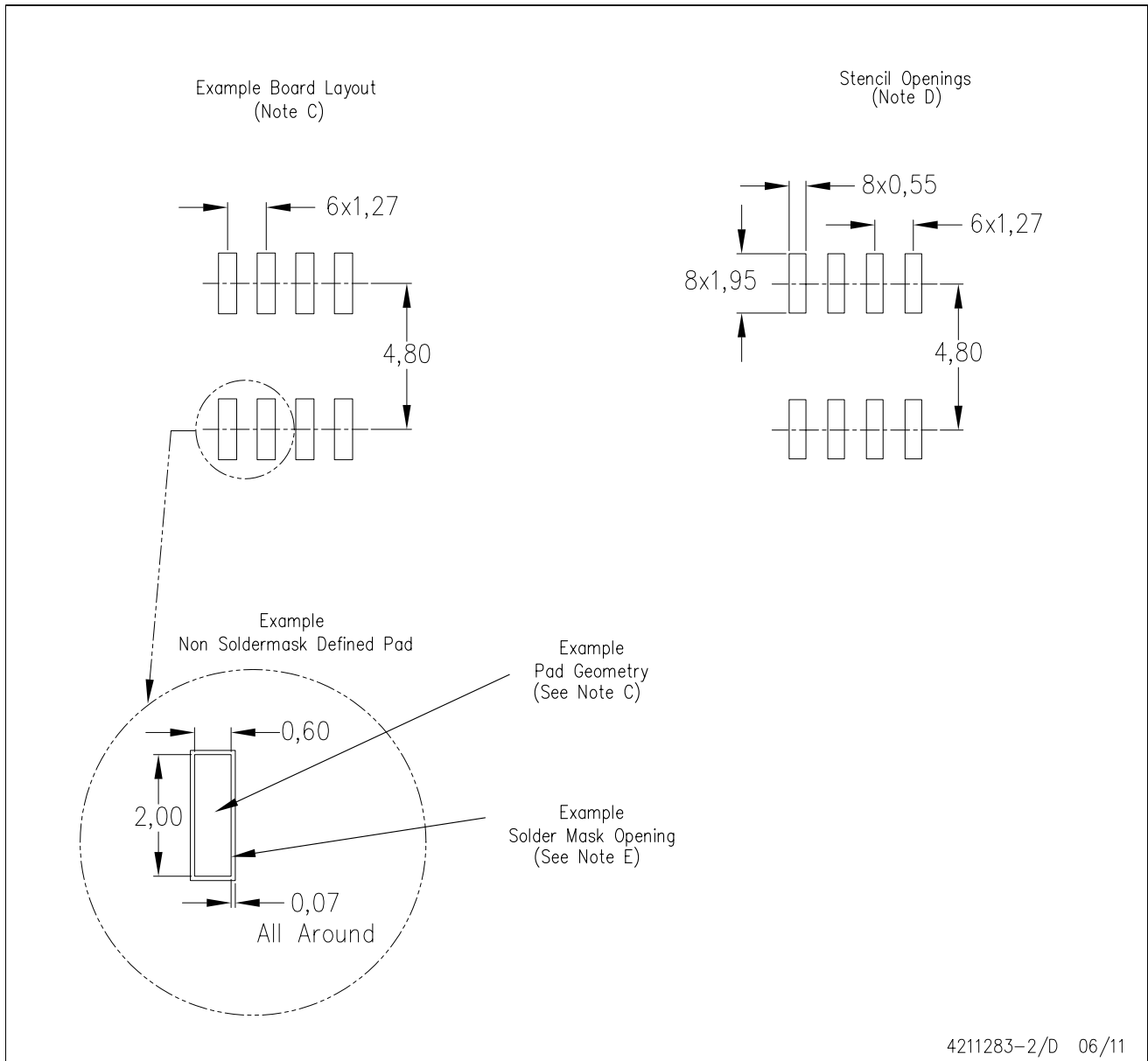

- NOTES:
- All linear dimensions are in millimeters.
 - This drawing is subject to change without notice.
 - Publication IPC-7351 is recommended for alternate designs.
 - Laser cutting apertures with trapezoidal walls and also rounding corners will offer better paste release. Customers should contact their board assembly site for stencil design recommendations. Refer to IPC-7525 for other stencil recommendations.
 - Customers should contact their board fabrication site for solder mask tolerances between and around signal pads.

PW (R-PDSO-G8)

PLASTIC SMALL OUTLINE

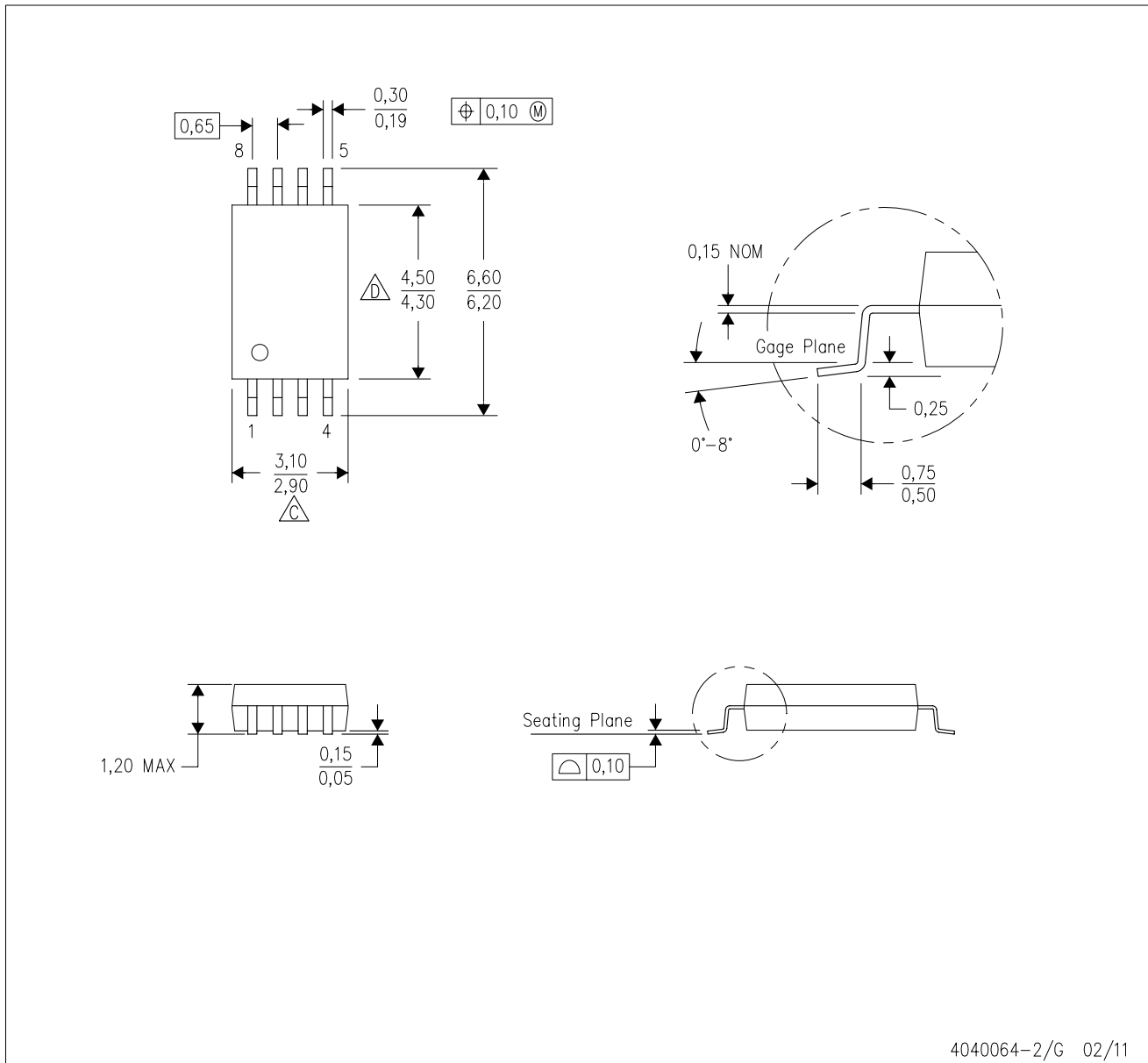

- NOTES:
- A. All linear dimensions are in millimeters. Dimensioning and tolerancing per ASME Y14.5M-1994.
 - B. This drawing is subject to change without notice.
 - C. Body length does not include mold flash, protrusions, or gate burrs. Mold flash, protrusions, or gate burrs shall not exceed 0,15 each side.
 - D. Body width does not include interlead flash. Interlead flash shall not exceed 0,25 each side.
 - E. Falls within JEDEC MO-153

IMPORTANT NOTICE

Texas Instruments Incorporated and its subsidiaries (TI) reserve the right to make corrections, modifications, enhancements, improvements, and other changes to its products and services at any time and to discontinue any product or service without notice. Customers should obtain the latest relevant information before placing orders and should verify that such information is current and complete. All products are sold subject to TI's terms and conditions of sale supplied at the time of order acknowledgment.

TI warrants performance of its hardware products to the specifications applicable at the time of sale in accordance with TI's standard warranty. Testing and other quality control techniques are used to the extent TI deems necessary to support this warranty. Except where mandated by government requirements, testing of all parameters of each product is not necessarily performed.

TI assumes no liability for applications assistance or customer product design. Customers are responsible for their products and applications using TI components. To minimize the risks associated with customer products and applications, customers should provide adequate design and operating safeguards.

TI does not warrant or represent that any license, either express or implied, is granted under any TI patent right, copyright, mask work right, or other TI intellectual property right relating to any combination, machine, or process in which TI products or services are used. Information published by TI regarding third-party products or services does not constitute a license from TI to use such products or services or a warranty or endorsement thereof. Use of such information may require a license from a third party under the patents or other intellectual property of the third party, or a license from TI under the patents or other intellectual property of TI.

Reproduction of TI information in TI data books or data sheets is permissible only if reproduction is without alteration and is accompanied by all associated warranties, conditions, limitations, and notices. Reproduction of this information with alteration is an unfair and deceptive business practice. TI is not responsible or liable for such altered documentation. Information of third parties may be subject to additional restrictions.

Resale of TI products or services with statements different from or beyond the parameters stated by TI for that product or service voids all express and any implied warranties for the associated TI product or service and is an unfair and deceptive business practice. TI is not responsible or liable for any such statements.

TI products are not authorized for use in safety-critical applications (such as life support) where a failure of the TI product would reasonably be expected to cause severe personal injury or death, unless officers of the parties have executed an agreement specifically governing such use. Buyers represent that they have all necessary expertise in the safety and regulatory ramifications of their applications, and acknowledge and agree that they are solely responsible for all legal, regulatory and safety-related requirements concerning their products and any use of TI products in such safety-critical applications, notwithstanding any applications-related information or support that may be provided by TI. Further, Buyers must fully indemnify TI and its representatives against any damages arising out of the use of TI products in such safety-critical applications.

TI products are neither designed nor intended for use in military/aerospace applications or environments unless the TI products are specifically designated by TI as military-grade or "enhanced plastic." Only products designated by TI as military-grade meet military specifications. Buyers acknowledge and agree that any such use of TI products which TI has not designated as military-grade is solely at the Buyer's risk, and that they are solely responsible for compliance with all legal and regulatory requirements in connection with such use.

TI products are neither designed nor intended for use in automotive applications or environments unless the specific TI products are designated by TI as compliant with ISO/TS 16949 requirements. Buyers acknowledge and agree that, if they use any non-designated products in automotive applications, TI will not be responsible for any failure to meet such requirements.

Following are URLs where you can obtain information on other Texas Instruments products and application solutions:

Products

| | |
|------------------------|--|
| Audio | www.ti.com/audio |
| Amplifiers | amplifier.ti.com |
| Data Converters | dataconverter.ti.com |
| DLP® Products | www.dlp.com |
| DSP | dsp.ti.com |
| Clocks and Timers | www.ti.com/clocks |
| Interface | interface.ti.com |
| Logic | logic.ti.com |
| Power Mgmt | power.ti.com |
| Microcontrollers | microcontroller.ti.com |
| RFID | www.ti-rfid.com |
| OMAP Mobile Processors | www.ti.com/omap |
| Wireless Connectivity | www.ti.com/wirelessconnectivity |

Applications

| | |
|-------------------------------|--|
| Automotive and Transportation | www.ti.com/automotive |
| Communications and Telecom | www.ti.com/communications |
| Computers and Peripherals | www.ti.com/computers |
| Consumer Electronics | www.ti.com/consumer-apps |
| Energy and Lighting | www.ti.com/energy |
| Industrial | www.ti.com/industrial |
| Medical | www.ti.com/medical |
| Security | www.ti.com/security |
| Space, Avionics and Defense | www.ti.com/space-avionics-defense |
| Video and Imaging | www.ti.com/video |

TI E2E Community Home Page

e2e.ti.com

Mailing Address: Texas Instruments, Post Office Box 655303, Dallas, Texas 75265
Copyright © 2012, Texas Instruments Incorporated